

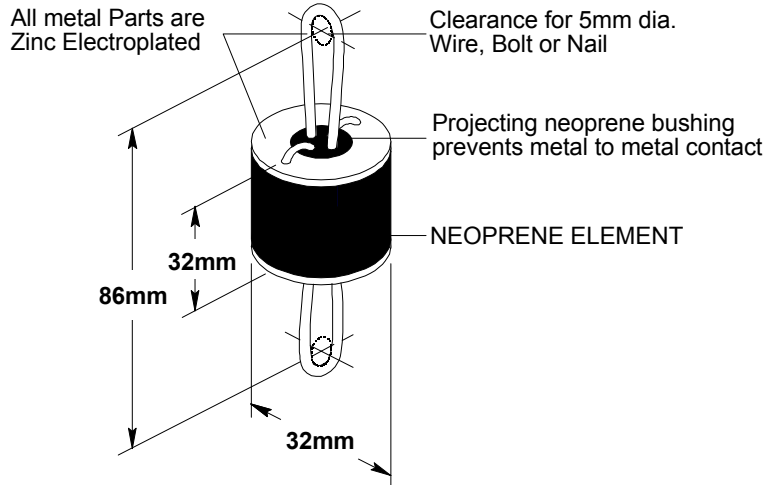

MASON INDUSTRIES, Inc.
Manufacturers of Vibration Control Products
 NY Mailing Address: PO Box 410, Smithtown, NY 11787
 350 Rabro Drive 2101 W. Crescent Ave., Suite D
 Hauppauge, NY 11788 Anaheim, CA 92801
 631/348-0282 714/535-2727
 FAX 631/348-0279 FAX 714/535-5738
 Info@Mason-Ind.com Info@MasonAnaheim.com

CERTIFIED FOR
JOB NAME :
CUSTOMER :
CUSTOMER P.O. :
MASON M.I. :
DWG. NO. :

TYPE
WHR
 Neoprene
 Ceiling Hangers



TYPE WHR RATINGS

Size (Duro-meter)	Rated Capacity Range [kg]	Rated Defl. [mm]	Color Mark
WHR-40	Up to 27	5	Green
WHR-50	23-43	5	Red
WHR-60	41-70	5	White
WHR-70	68-100	5	Yellow

Hanger elements have straight line deflection curves.

NOTE - Tested to Failure at 546kg.

CERTIFICATION DATA

_____ inch SPECIFIED DEFLECTION

TAG : _____
 UNIT : _____

DWN : _____ CHKD: _____ DATE : _____

DWG NO. : _____