



**MASON U.K.**

VIBRATION CONTROL PRODUCTS AND  
ACOUSTIC FLOOR SYSTEMS

## **HDLP-X**

### **Low Profile Ceiling Hanger**

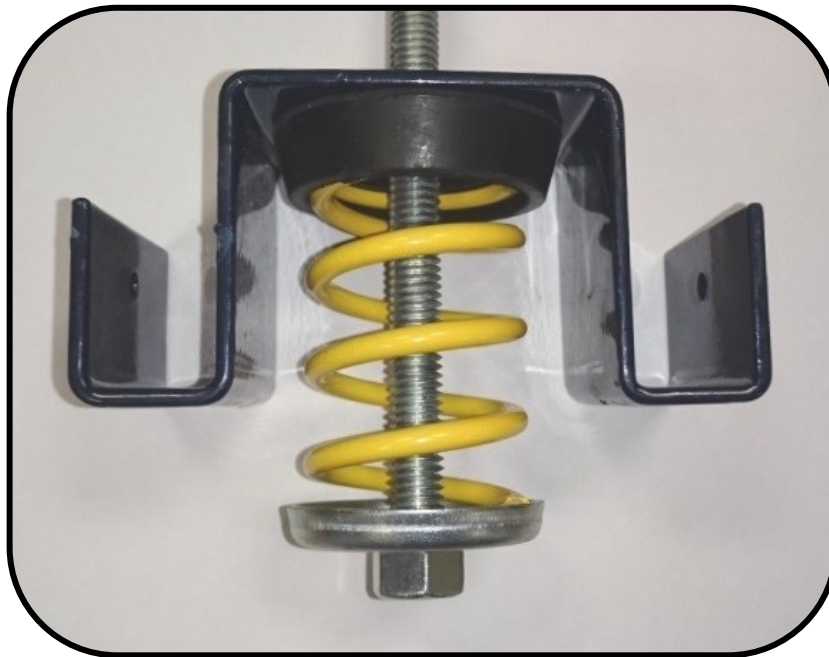

- Allows for compact suspended ceiling installations
- Allows for quick and easy installation of most metal grid ceiling systems
- The hangers can support ceiling weights of up to 59kg per hanger
- The spring elements can provide up to 25mm deflection, providing natural frequencies down to 3.2Hz.
- The high quality spring element provides isolation against impact and low frequency noise, such as that from mechanical sources.
- The spring sits in a neoprene cup which absorbs high frequency energy.

Mason U.K. Ltd.  
Unit 6 Abbey Business Park  
Monks Walk  
Farnham, Surrey  
GU9 8HT

Phone: 01252 716610  
Fax: 01252 716630  
E-mail: [info@mason-uk-co.uk](mailto:info@mason-uk-co.uk)  
Web: [www.mason-uk.co.uk](http://www.mason-uk.co.uk)

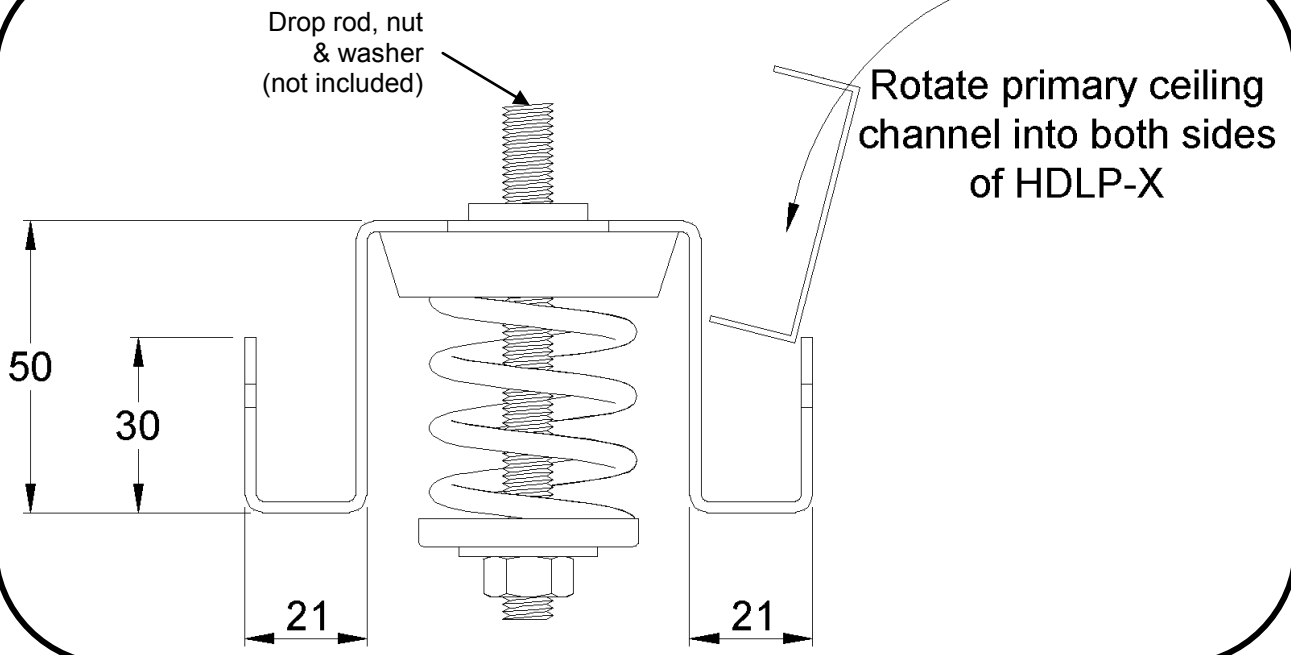

	<i>Rated capacity (kg)</i>	<i>Rated deflection (mm)</i>	<i>Rated Natural Frequency (Hz)</i>
<i>HDLP-X-23</i>	10	33	2.8
<i>HDLP-X-33</i>	15	28	3.0
<i>HDLP-X-54</i>	24	25	3.2
<i>HDLP-X-76</i>	34	25	3.2
<i>HDLP-X-113</i>	51	25	3.2
<i>HDLP-X-130</i>	59	25	3.2

## NOTE

- Mason HDLP-X series spring hangers can compress up to 25mm at rated capacity.
- Please allow for the compression of the spring hanger when installing ceiling systems.

Mason U.K. Ltd.  
Unit 6 Abbey Business Park  
Monks Walk  
Farnham, Surrey  
GU9 8HT

Phone: 01252 716610  
Fax: 01252 716630  
E-mail: [info@mason-uk-co.uk](mailto:info@mason-uk-co.uk)  
Web: [www.mason-uk.co.uk](http://www.mason-uk.co.uk)

## Typical Installation for Mason HDLP-X Series Spring Hangers

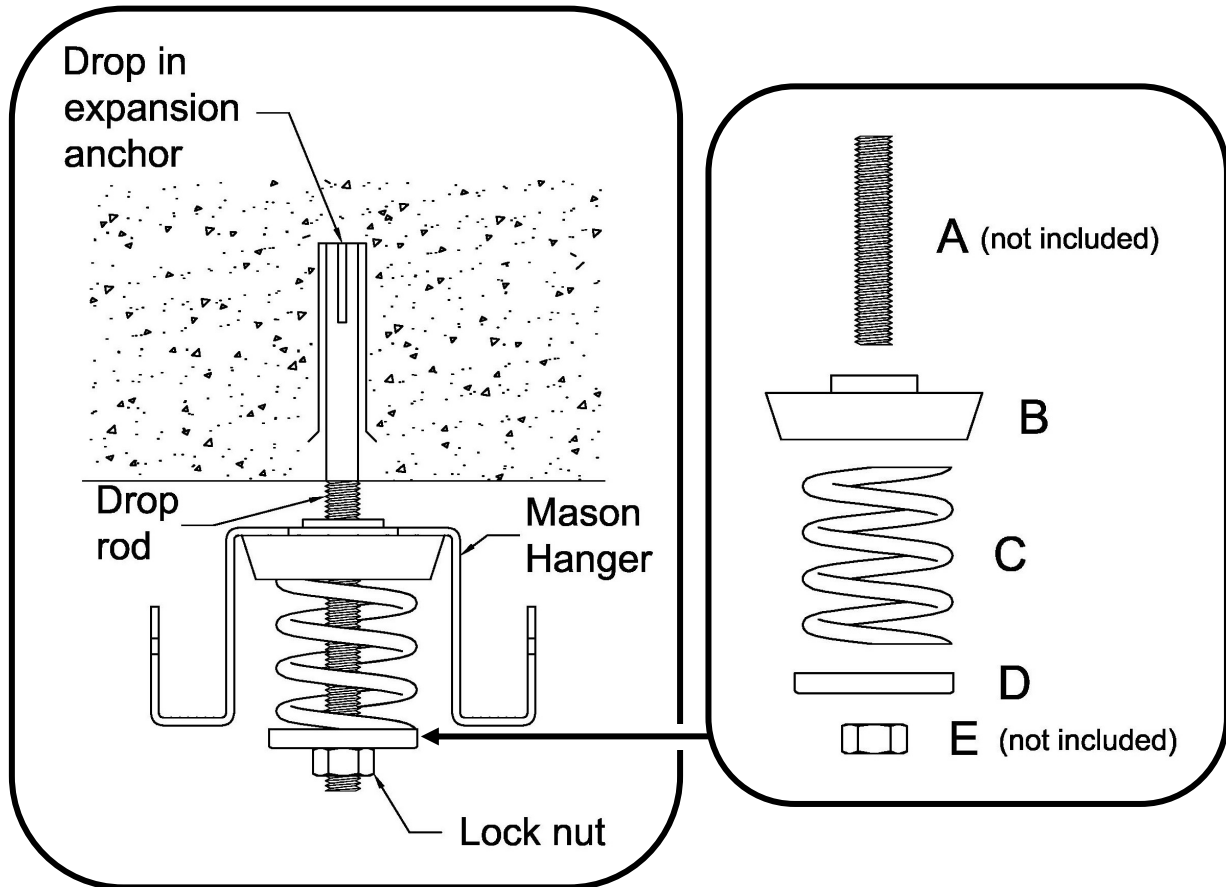

<b>A</b>	-	Drop Rod (not supplied)
<b>B</b>	-	Rubber cup
<b>C</b>	-	Spring element
<b>D</b>	-	Metal cup
<b>E</b>	-	Self-locking nut (not supplied)

### Installation instructions:

- Fix the top of the drop rod to the soffit, bracket or ceiling joist as required.
- Assemble the hanger as above.
- If desired, pre-compress spring with large penny washer and nut on top by a maximum of 10mm.
- Set all the hangers to the same height by laser or similar method.
- Install the ceiling system in the normal way.

Mason U.K. Ltd.  
Unit 6 Abbey Business Park  
Monks Walk  
Farnham, Surrey  
GU9 8HT

Phone: 01252 716610  
Fax: 01252 716630  
E-mail: [info@mason-uk.co.uk](mailto:info@mason-uk.co.uk)  
Web: [www.mason-uk.co.uk](http://www.mason-uk.co.uk)