



MASON INDUSTRIES, Inc.

MERCER RUBBER Co.

350 Rabro Drive, Hauppauge, NY 11788
 Mason- 631/348-0282 • Info@Mason-Ind.com
 Mercer- 631/582-1524 • Info@Mercer-Rubber.com
 FAX 631/348-0279



JOB NAME _____
 CUSTOMER _____
 CUSTOMER P.O. _____
 MASON M. _____
 DWG No. _____

SPG

TYPICAL
 SPIDER
 PIPE
 GUIDES

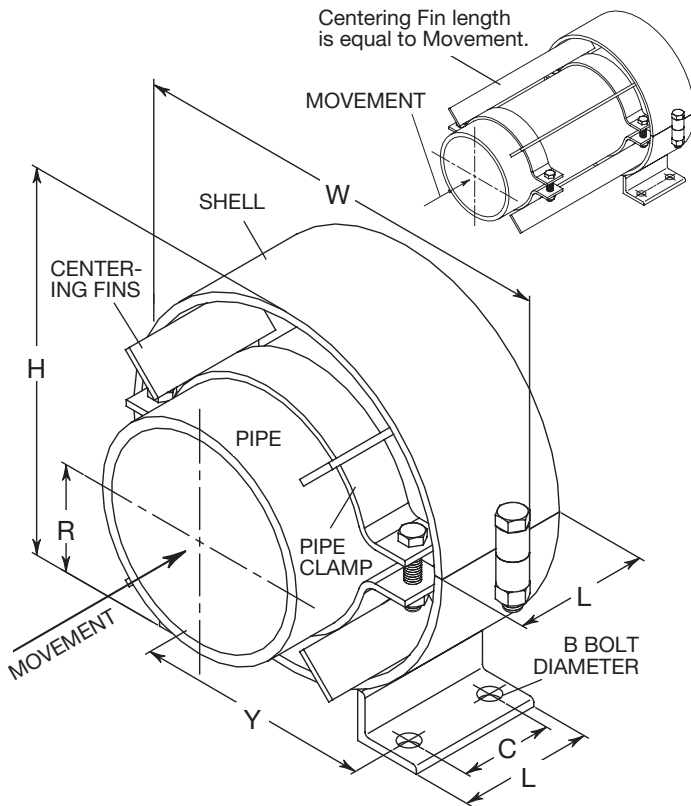

Shell Codes AA through FF have one clamp;
 Shell Codes GG through PP have two clamps.

**SPG SHELL SELECTION TABLE for
 4" (100mm), 6" (150mm) & 8" (200mm) MOVEMENT**

Pipe Size (in)(mm)	SHELL CODE LETTERS							Max. Standard Mvmt.±* (in)(mm)
	Insulation Thickness							
	1" 25mm	1 1/2" 32mm	2" 50mm	2 1/2" 65mm	3" 80mm	3 1/2" 90mm	4" 100mm	
1/2 15	AA	AA	BB	DD	DD	DD	EE	4 100
3/4 20	AA	BB	CC	DD	DD	DD	EE	4 100
1 25	AA	BB	CC	DD	DD	EE	EE	4 100
1 1/4 32	AA	BB	CC	DD	DD	EE	EE	4 100
1 1/2 40	BB	BB	CC	DD	DD	EE	EE	4 100
2 50	BB	CC	DD	DD	EE	EE	FF	4 100
2 1/2 65	CC	CC	DD	DD	EE	EE	FF	4 100
3 80	CC	DD	DD	EE	FF	FF	FF	4 100
4 100	DD	DD	EE	EE	FF	FF	GG	6 150
5 125	EE	EE	EE	FF	FF	GG	HH	6 150
6 150	EE	EE	FF	FF	GG	HH	HH	6 150
8 200	FF	FF	GG	HH	HH	JJ	JJ	6 150
10 250	HH	HH	HH	JJ	JJ	KK	KK	6 150
12 300	JJ	JJ	JJ	KK	KK	LL	LL	8 200
14 350	KK	KK	KK	KK	LL	LL	MM	8 200
16 400	LL	LL	LL	LL	MM	MM	NN	8 200
18 450	MM	MM	MM	MM	NN	NN	NN	8 200
20 500	NN	NN	NN	NN	PP	PP	PP	8 200
24 600	PP	PP	PP	PP	—	—	—	8 200

*Centering Fin length is equal to the Maximum Standard Movement.
 Non-standard movements are available.

SPG DIMENSIONS (inches)

Type	Shell Code	H	R	W	Y	B	C	L
SPG	AA	57/8	31/2	61/8	41/8	5/8	13/4	3
SPG	BB	63/4	4	71/8	43/8	5/8	13/4	3
SPG	CC	75/8	43/8	81/8	51/8	5/8	13/4	3
SPG	DD	91/4	51/4	101/8	61/8	5/8	13/4	3
SPG	EE	115/8	61/4	121/8	7	5/8	23/4	4
SPG	FF	133/8	7	141/8	81/4	5/8	23/4	4
SPG	GG	151/8	77/8	161/8	97/8	3/4	4	6
SPG	HH	17	87/8	181/8	107/8	3/4	4	6
SPG	JJ	183/4	93/4	201/8	117/8	3/4	4	6
SPG	KK	21	107/8	221/8	113/4	3/4	6	8
SPG	LL	231/8	121/8	241/8	141/2	7/8	6	8
SPG	MM	25	13	261/8	151/2	7/8	6	8
SPG	NN	273/4	143/4	281/8	171/8	11/8	6	8
SPG	PP	311/2	161/2	321/8	191/4	11/8	6	8

SPG DIMENSIONS (mm)

Type	Shell Code	H	R	W	Y	B	C	L
SPG	AA	149	90	156	104	16	44	76
SPG	BB	171	102	181	111	16	44	76
SPG	CC	194	111	206	130	16	44	76
SPG	DD	235	133	257	156	16	44	76
SPG	EE	295	159	308	178	16	70	102
SPG	FF	340	178	360	210	16	70	102
SPG	GG	384	200	410	251	19	102	152
SPG	HH	432	225	460	276	19	102	152
SPG	JJ	476	248	511	302	19	102	152
SPG	KK	533	276	562	298	19	152	203
SPG	LL	587	308	613	368	22	152	203
SPG	MM	635	330	664	394	22	152	203
SPG	NN	705	375	714	435	22	152	203
SPG	PP	800	419	816	489	22	152	203

QUANTITY	PIPE SIZE	INSULATION	MOVEMENT	SHELL CODE	TAG