



MASON INDUSTRIES, Inc.

Manufacturers of Vibration Control Products

350 Rabro Drive
Hauppauge, NY 11788
631/348-0282
FAX 631/348-0279
Info@Mason-Ind.com

2101 W. Crescent Ave., Suite D
Anaheim, CA 92801
714/535-2727
FAX 714/535-5738
Info@MasonAnaheim.com
www.Mason-Ind.com

JOB NAME _____
CUSTOMER _____
CUSTOMER P.O. _____
MASON M. _____
DWG No. _____

SLF

**4" 100mm
Deflection
100 Series
Spring Mounts**

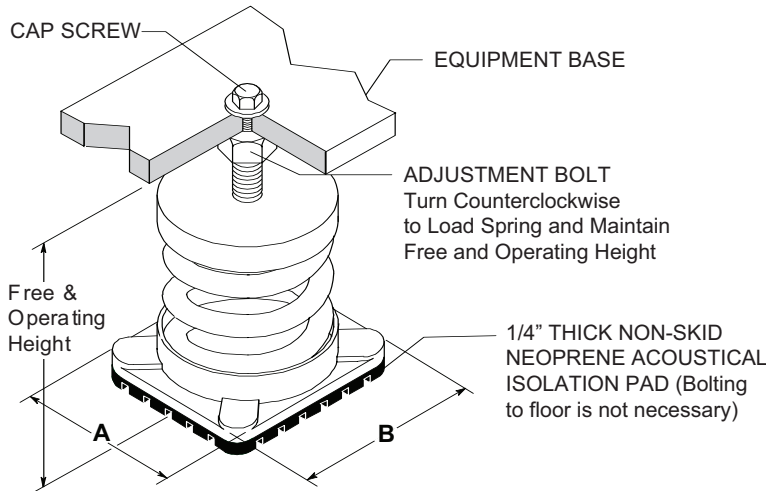

Cap Screw secures Height Saving Bracket (or Equipment Base) to Tapped Concentric Hole in Mounting Adjustment Bolt.

All springs have additional travel to solid equal to 50% of the rated deflection.

Solid Spring Height = Free Height minus 1.5 times Rated Deflection.

OD/OH = Ratio of Spring Outside Diameter to Operating Height
= 0.82 - 1.15

Holders for mounts SLF-150 thru SLF-164 are castings. Holders for mounts SLF-165 thru SLF-169 are steel.

TYPE SLF LOAD RATINGS and DIMENSIONS (inches mm)

Type and Size	Rated Capacity (lbs) (kg)	Rated Defl. (in) (mm)	Mount Constant (lbs/in)(kg/mm)	Spring Color/Stripe	Spring Only		Free & Oper Ht	A	B	Adjustment Bolt AB	Locking Cap Screw CS
					Spring OD	Free Height					
SLF-150	240 109	4.38 121	55 0.98	Purple	5	127	83/8 213				
SLF-151	330 150	4.38 121	75 1.35	Brown	5	127	81/2 213				
SLF-152	420 191	4.38 121	95 1.72	Orange	5	127	83/8 213				
SLF-153	530 240	4.38 121	120 2.16	Green	5	127	83/8 213				
SLF-154	680 308	4.38 121	155 2.77	Red	6	152	87/8 225	103/4 273	65/8 168	71/2 191	
SLF-155	880 399	4.38 121	200 3.59	White	6	152	91/8 232	103/4 273	65/8 168	71/2 191	1 x 8 x 203
SLF-156	1120 508	4.38 121	255 4.58	Blue	6	152	97/8 251	12 305	65/8 168	71/2 191	1/2x11/4 x 32
SLF-157	1420 644	4.38 121	325 5.80	Black	6	152	10 254	12 305	65/8 168	71/2 191	
SLF-158	1840 835	4.38 121	420 7.52	Yellow	6 3/4	171	103/8 264	12 1/8 308	7 1/2 191	7 1/2 191	1 x 8 x 203
SLF-159	2370 1075	4.38 121	540 9.68	Gray	6 3/4	171	11 1/8 283	13 330	7 1/2 191	7 1/2 191	5/8x11/2 x 38
SLF-160	3000 1361	4.38 121	695 12.26	Blue/Brwn	7 3/4	197	107/8 276	13 330	8 1/2 216	8 1/2 216	1 1/4 x 8 x 203
SLF-161	3900 1769	4.38 121	895 15.94	Blue/Red	7 3/4	197	113/8 289	13 1/2 343	8 1/2 216	8 1/2 216	5/8x11/2 x 38
SLF-162	5100 2313	4.38 121	1155 20.84	Blue/Orng	8 3/4	222	11 1/2 292	14 356	9 1/2 241	9 1/2 241	
SLF-163	6500 2948	4.38 121	1485 26.56	Blue/White	8 3/4	222	13 1/4 337	16 406	9 1/2 241	9 1/2 241	1 1/2 x 8 x 203
SLF-164	8400 3810	4.38 121	1910 34.32	Blue/Silver	8 3/4	222	133/8 340	16 406	9 1/2 241	9 1/2 241	3/4 x 2 x 51
SLF-165	10800 4899	4.38 121	2455 44.14	Blue/Gray	9 3/8	238	14 1/8 359	17 432	10 1/2 267	10 1/2 267	
SLF-166	13800 6260	4.38 121	3160 56.40	Blue/Green	10	254	153/8 391	19 483	11 279	11 279	13/4 x 8 x 203
SLF-167	17800 8074	4.38 121	4065 72.74	Blue/Yellow	11	279	157/8 403	19 483	12 305	12 305	3/4 x 2 x 51
SLF-168	22900 10387	4.38 121	5235 93.58	Blue/Pink	11	279	17 432	20 508	12 305	12 305	2 x 8 x 203
SLF-169	30000 13608	4.38 121	6730 122.59	Blue/Tan	11 5/8	295	18 457	21 533	13 330	13 330	1 x 2 1/2 x 76

PLAN VIEW OF MOUNT LOCATIONS

TAG: _____
UNIT: _____



SPECIFIED DEFLECTION

1:	6:
2:	7:
3:	8:
4:	9:
5:	10:
Sets Required:	