



MASON INDUSTRIES, Inc.

Manufacturers of Vibration Control Products

350 Rabro Drive 2101 W. Crescent Ave., Suite D
 Hauppauge, NY 11788 Anaheim, CA 92801
 631/348-0282 714/535-2727
 FAX 631/348-0279 FAX 714/535-5738
 Info@Mason-Ind.com Info@MasonAnaheim.com

JOB NAME _____
 CUSTOMER _____
 CUSTOMER P.O. _____
 MASON M.I. _____
 DWG. NO. _____

SLF

5" Deflection
 Free Standing
 Spring Mounts

Cap Screw secures Height Saving Bracket (or Equipment Base) to Tapped Concentric Hole in Mounting Adjustment Bolt.

For mounts SLF-174 thru SLF-182:

Cap Screws are: 1/2" x 1 1/4"

For mounts SLF-183 thru SLF-186:

Cap Screws are: 5/8" x 1 1/2"

For mounts SLF-187 thru SLF-193:

Cap Screws are: 3/4" x 2"

For mounts SLF-194 thru SLF-198:

Cap Screws are: 1" x 2 1/2"

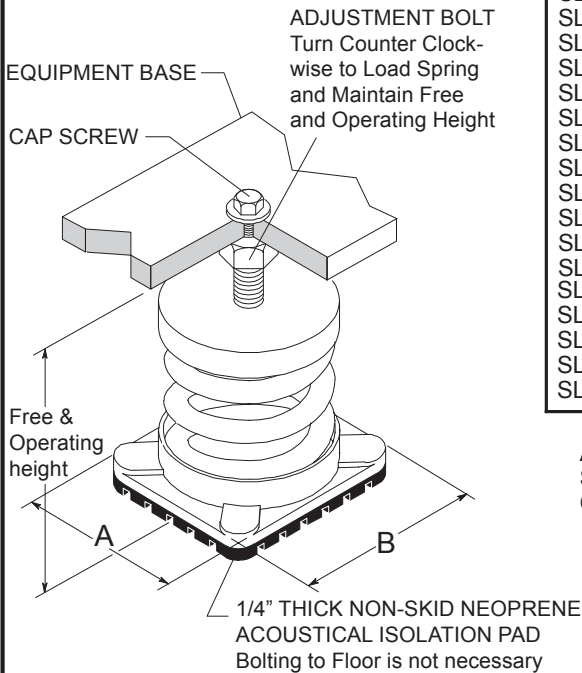

TYPE SLF LOAD RATINGS and DIMENSIONS (inches)

Size	Rated Capacity (lbs)	Rated Defl. (in)	Mount Constant (lbs/in)	Spring Only			Free & Oper. Ht	Complete Mount	
				OD	Ht	Spring Color/Stripe		A	B
SLF-174	270	5.31	50	6	9 7/8	Purple	12	6 5/8	7 1/2
SLF-175	320	5.31	60	6	10	Brown	12	6 5/8	7 1/2
SLF-176	370	5.31	70	6	10	Orange	12	6 5/8	7 1/2
SLF-177	460	5.38	85	6	10 1/2	Green	12	6 5/8	7 1/2
SLF-178	560	5.38	105	6	10 3/4	Red	12 5/8	6 5/8	7 1/2
SLF-179	670	5.38	125	6 3/4	11 1/8	White	13 1/4	7 1/2	7 1/2
SLF-180	830	5.38	155	6 3/4	11 3/8	Blue	13 1/4	7 1/2	7 1/2
SLF-181	1000	5.38	185	6 3/4	11 1/8	Black	13 1/4	7 1/2	7 1/2
SLF-182	1240	5.37	230	6 3/4	11 3/8	Yellow	13 1/4	7 1/2	7 1/2
SLF-183	1500	5.37	280	7 3/4	12 1/2	Gray	15	8 1/2	8 1/2
SLF-184	1830	5.37	340	7 3/4	11 7/8	Pink	15	8 1/2	8 1/2
SLF-185	2230	5.37	415	7 3/4	12	Silver	15	8 1/2	8 1/2
SLF-186	2710	5.37	505	7 3/4	12 3/4	Tan	15	8 1/2	8 1/2
SLF-187	3300	5.37	615	8 3/4	12 3/4	Blue / Org	15 1/2	9 1/2	9 1/2
SLF-188	4100	5.37	755	8 3/4	13 3/8	Blue / Red	16	9 1/2	9 1/2
SLF-189	4900	5.37	915	9 1/8	13 1/2	Blue / White	16	9 1/2	9 1/2
SLF-190	6000	5.37	1120	9 1/2	14 5/8	Blue / Yellow	17	10 1/2	10 1/2
SLF-191	7300	5.37	1365	9 1/2	15 1/4	Blue / Silvr	17 1/2	10 1/2	10 1/2
SLF-192	9000	5.37	1670	10 1/4	15 5/8	Blue / Gray	18	11	11
SLF-193	11000	5.37	2040	10 1/4	16	Blue / Tan	18	11	11
SLF-194	13300	5.37	2482	11	16 1/4	Blue / Brwn	19	12	12
SLF-195	16300	5.37	3028	11 3/8	17 1/8	Blue / Pink	20	12	12
SLF-196	19800	5.37	3694	11 5/8	18	Blue / Blck	21	13	13
SLF-197	24200	5.37	4506	13	19 1/2	Blue / Gm	23	14	14
SLF-198	29000	5.27	5500	13	19 1/8	Blue / Prpl	23	14	14

All springs have additional travel to solid equal to 50% of the rated deflection.
 Solid Spring Height = Free Height minus 1.5 times Rated Deflection.
 OD/OH = Ratio of Spring Outside Diameter to Operating Height = 0.9 - 1.23

Holders for mounts SLF-174 thru SLF-188 are castings.
 Holders for mounts SLF-189 thru SLF-198 are steel.

CERTIFICATION DATA

TAG : _____

UNIT : _____

PLAN VIEW OF MOUNT LOCATION:



SPECIFIED DEFLECTION

1 :	6 :
2 :	7 :
3 :	8 :
4 :	9 :
5 :	10 :

Sets Required: _____